

Bearing Unit

LSQFR 309 TQT.H.T

Bearing Unit
Packer Roller

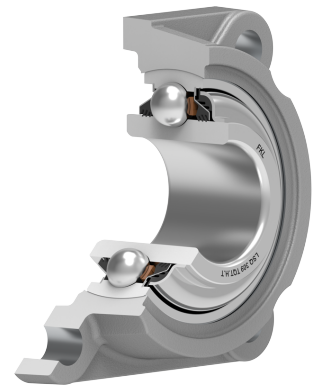
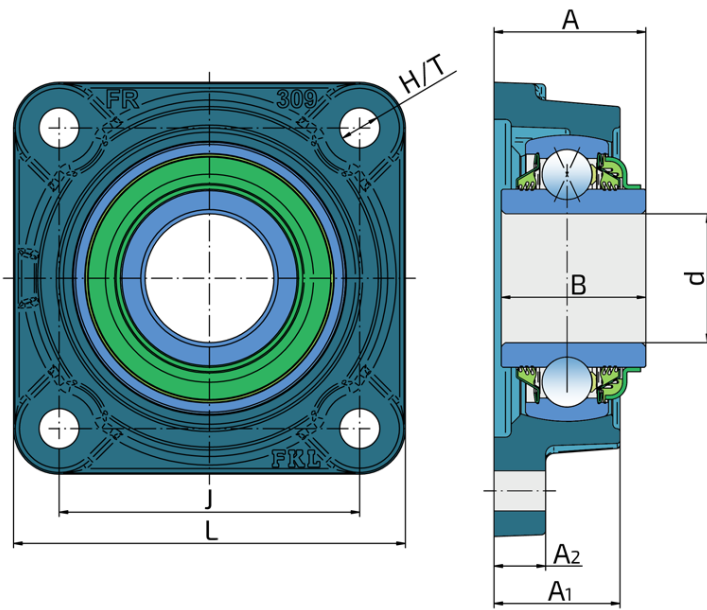

Technical Specification

d	Bore diameter	45 mm
L	Total length	137 mm
J	Distance between the holes	105 mm
H/T	Hole/Thread	14 mm
A	Overall width	53 mm
A1	Total housing width	44 mm
A2	Housing flange thickness	18 mm
B	Width inner ring	50.45 mm
kg	Mass	3.061 kg
Cdyn	Dynamic load rating	80.8 kN
Co	Static load rating	59.6 kN
Pu	Fatigue load limit	2.503 kN

Sealing

TQ SEAL / T SEAL

3-lip seal on the base side and 7-lip seal on the front side which is exposed to contaminants. The innovative 7-lip seal ensures a perfect fit on the inner ring, delivering exceptional sealing performance and durability even under extreme conditions. The TQT seal effectively prevent the ingress of water, snow, mud, and dust, providing robust protection of the bearing and extending its lifetime.

