

# Bearing Unit

## LSQFR 308 2TD.H.T

Bearing Unit  
Packer Roller

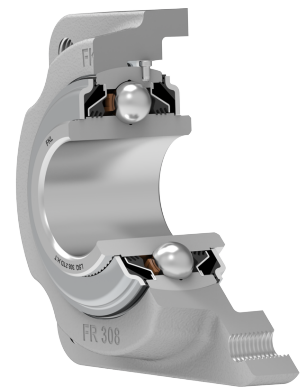
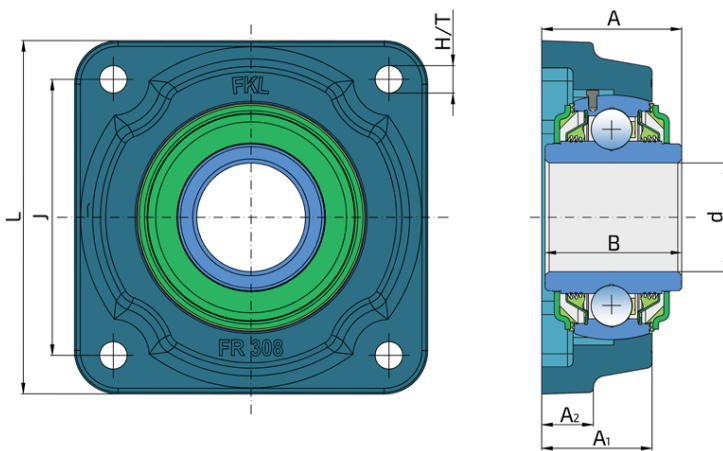

### Technical Specification

d	Bore diameter	40 mm
L	Total length	130 mm
J	Distance between the holes	101.5 mm
H/T	Hole/Thread	4x13 mm
A	Overall width	48.4 mm
A1	Total housing width	40.6 mm
A2	Housing flange thickness	19 mm
B	Width inner ring	45.8 mm
kg	Mass	2.51 kg
Cdyn	Dynamic load rating	41 kN
Co	Static load rating	24 kN
Pu	Fatigue load limit	1.01 kN

## Sealing

---

### RUBBERIZED FLINGER + T SEAL / T SEAL + RUBBERIZED FLINGER

Rubberized flinger with 3-lip seal on the base side and 3-lip seal with rubberized flinger on the front side which is exposed to contaminants. The 3-lip seal protects the bearing from contaminant penetration. The rubberized flinger protects the seal from mechanical damage and provides additional sealing.

