

# Trunnion Bearing Units

## GWHGR 211PP202

Trunnion Bearing Units  
Disc Harrow

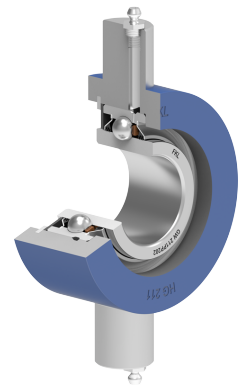
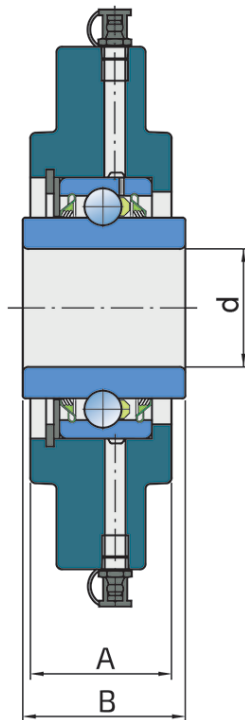
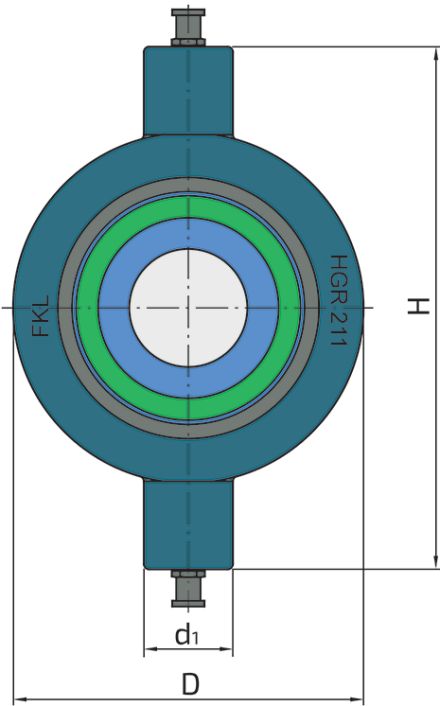

### Technical Specification

d	Bore diameter	51.308 mm
d1	Bearing housing sleeve diameter	37 mm
D	Outside diameter	129.5 mm
A	Overall width	57 mm
B	Width inner ring	60.3 mm
H	Housing height	202.5 mm
kg	Mass	4.8 kg
Cdyn	Dynamic load rating	43.5 kN
Co	Static load rating	29 kN
Pu	Fatigue load limit	1.218 kN

## Sealing

---

### T SEAL / T SEAL (2T)

3-lip seal on the both side of the bearing, provides equal protection against contamination. Recommended for application where the possibility of contamination is the same on the both side.

