

# Rubberized Bearing Unit

## GWR 211PPB21

Rubberized Bearing Unit  
Disc Harrow

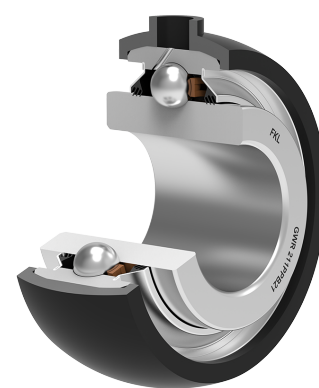
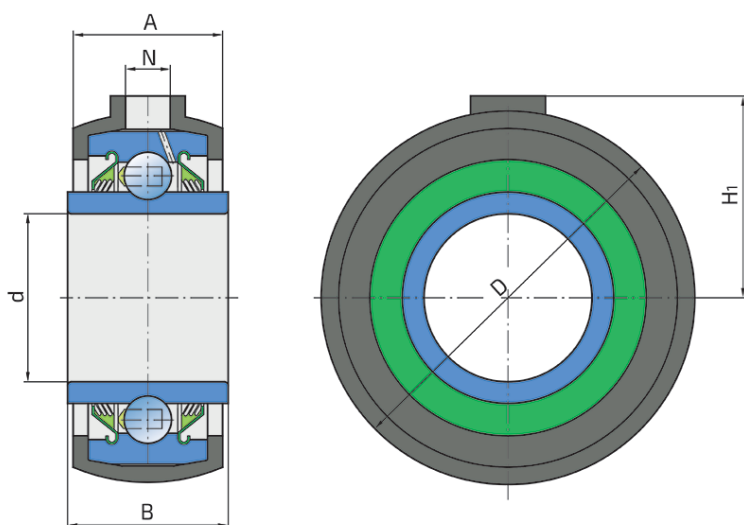

### Technical Specification

C <sub>dyn</sub>	Dynamic load rating	43.5 kN
C <sub>o</sub>	Static load rating	29 kN
D	Outside diameter	113 mm
d	Bore diameter	45.212 mm
kg	Mass	1.62 kg
H <sub>1</sub>	Distance from the contact surface to the bearing axis	60.5 mm
B	Width inner ring	53.975 mm
N	Hole diameter	12.7 mm
A	Overall width	44.7 mm

## Sealing

---

### T SEAL / T SEAL (2T)

3-lip seal on the both side of the bearing, provides equal protection against contamination. Recommended for application where the possibility of contamination is the same on the both side.

